

moveXX

driven by brain power



DATASHEET
Movexx T1000-P



Specifications T1000-P

Frame	Steel, powder coated
Drive	24V DC, 300W, 100 rpm
Weight	154kg
Weight trailer	Max. 1000 kg
Battery	Exchangable batterypack
Speed	Max. 3,8 km/h, freely programmable
Drive wheels	Vulcalon $\varnothing 200 \times 55$ mm
Width	423mm
Length	1278mm
Adze height	950-1146mm (variable)
Folded	950mm
Noise level	63,8 dB
To use from	-40 °C / 70 °C
Protection class	Machine IP44
Lifting capacity	600 kg
Lifting capacity	600 kg

Pulling power T1000-P (in kg)

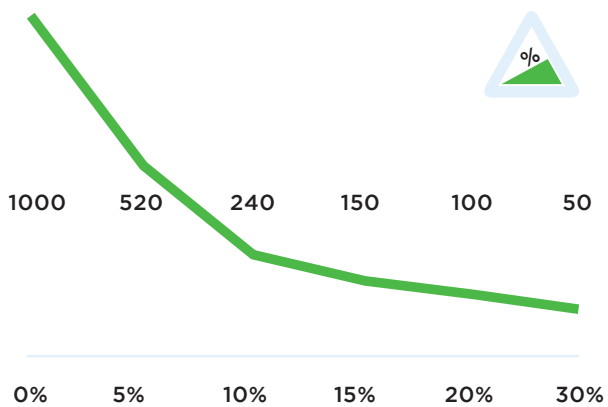

*Measured with a trolley with 2 swivelwheels and 2 fixed castors. Wheel diameter: 160mm

Dimensions T1000-P

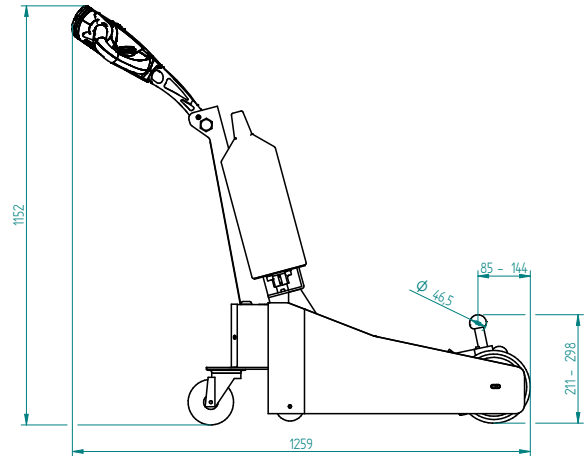
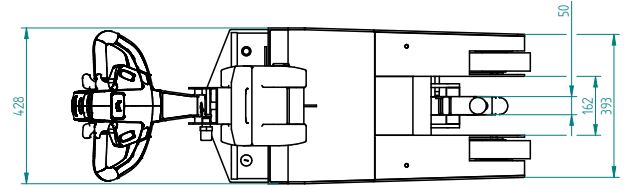

Standard T1000-P



Standard parts T1000-P

Charger 24V 5A incl. charging cable



Item number:
OPT0009

Batterie AGM 22Ah



Item number:
OPT0110-RAL6018

Drive wheel Ø200
B50 d20 mm



Item number:
M0340

Adjustable tillerhead



Item number:
Standardpart 1

Safety switch



Item number:
Standardpart 2

2 programmable speeds



Item number:
Standardpart 3

Standard parts T1000-P

Motor T1000, without brake



Item number:
M1032

LED battery indicator
LBF318-24V



Item number:
M0123

Options T1000-P



**Battery Lithium-LiFe-
PO4, 36Ah GREEN**

Article number:
OPT0106



**Battery upgrade to
Lithium-LiFePO4,
36Ah**

*iso AGM Battery (!) Inclu-
ding upgrade to lithium
charger 10A*

Article number:
OPT0107



Batterie AGM 22Ah

Article number:
OPT0110-RAL6018



Horn 90dB

Article number:
OPT0045



**Emergency stop
complete**

Article number:
OPT0063



**Strobelight cast iron
tiller head**

Article number:
OPT0076

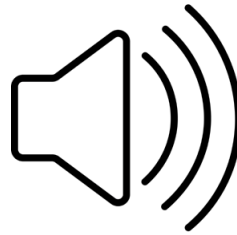

**Acoustic signal dri-
ving backwards**

Article number:
OPT0254



**hour counter com-
plete**

Article number:
OPT0056



Antistatic strip

Article number:
OPT0058



Code lock

Article number:
OPT0068



Document holder

Article number:
OPT0127



**Ignition key unequal
key**

Article number:
OPT0145

Options T1000-P

Ignition key equal key 701



Article number:
OPT0146

Customized programming



please indicate specific settings

Article number:
OPT0170

Programmer for Ital-sea



Article number:
D0003

Wall mounted Charger, for AGM battery



Complete charger-unit including AGM battery charger (5 Ah)

Article number:
OPT0015

Charging Station for 1 Lithium battery



Wallmounting charger-station with lithium battery charger 29,2 V, 10 A

Article number:
OPT0023

Charging station for 5 Lithium batteries



Upright standing charging station with five separate lithium battery chargers 29,2 V, 10 A

Article number:
OPT0029

Charging station for 5 batteries



Upright standing charging station with five separate AGM battery chargers 24 V, 5 A

Article number:
OPT0039

Frame for charging station



for wall mounting, Excluding charger (!)

Article number:
OPT0261

25mm higher ball L=145



Article number:
OPT0192

Ball, height: 60mm for T1000-P



Article number:
OPT0183

Safety fender castor T1000-P

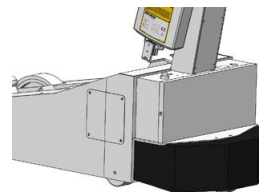

Article number:
OPT0212

50 mm higher ball T2500-P



Article number:
OPT0215

Options T1000-P



Tow Ball Ø 45mm L =
155mm T1000-P

Article number:
OPT0224



Plastic bumper strips
side T1000-P

Article number:
OPT0229



Slow speed with load
T1000-P

Article number:
OPT0230

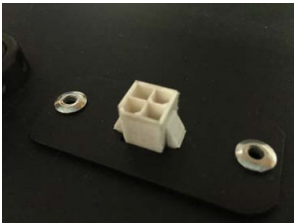

Diagnostic connector

Article number:
OPT0270

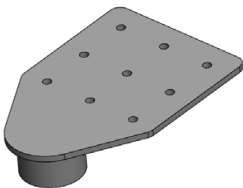

Screw tube for
T1000-P + T2500-P

Article number:
OPT0301



Movexx International B.V.

Generatorstraat 17

3903 LH Veenendaal

Tel +31 (0)318 51.99.00

Fax +31 (0)318 50.80.20

E-mail info@movexx.nl